

# MOL 540 Oil Burner



## **MOL 540 Oil Burner features:**

- Energy saving and compatible with environmental requirements
- Quiet in operation and designed for easy maintenance
- Reliable and trouble-free
- Designed and approved in accordance with the European Standard EN 267
- Suitable for high resistance boilers
- Industry standard components easily available
- Designed for high/low operation
- Plug-in contact facilitates the installation
- With hydraulic air adjustment
- Fuel – Light distillate oil Class D (1.5-5.5 cSt @ 40°C)
- All kW ratings are nett CV



For more information on Mechmar products  
please visit [www.mechmar.com.sg](http://www.mechmar.com.sg)

**MECHMAR**®

Type		MOL 540
Capacity	kW	101-540
Motor	V/Hz	230/50
	W / A (Fuse)	450 / 10
Start / Run Current	Amps	12.0 / 3.3
Control box		Landis & Staefa
Fuel pump		Danfoss/Suntec
2-Stage		•
Gross weight	kg	34
Volume	m <sup>3</sup>	0.22

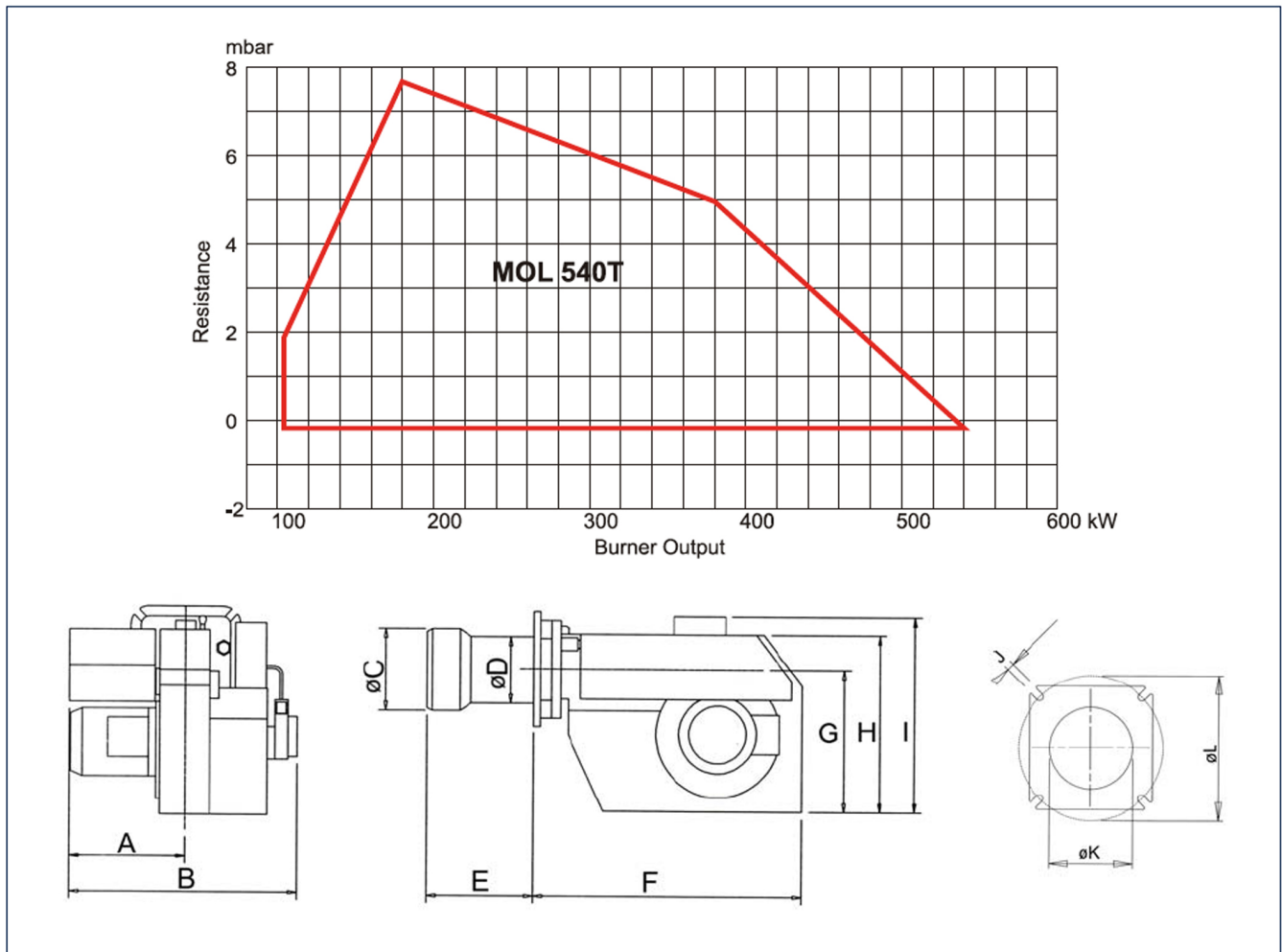

Burner	A	B	øC	øD	E*	F	G	H	I	J	øK	L
MOL 540T	262	515	162	134	240	480	252	328	335	14	134	200-260

\* Extended lengths Available

**MECHMAR (PTE) LTD**  
 56 Kian Teck Road Singapore 628791  
 Tel: 6268 3048 Fax: 6261 4049  
 E-mail: mechmar@singnet.com.sg  
 Website: www.mechmar.com.sg

